

# HCN

## Terminal units slim/reduced with Brushless DC and AC Asynchronous motor

6 kW ÷ 20 kW



- Self-supporting structure in galvanised sheet metal with thermal-acoustic insulation (S version) or 20 mm double sandwich panel with pre-painted white RAL 9002 external sheet metal (D version); with ceiling/wall fixing holes, small size and optimised overall dimensions.
- Double-sloped condensate drip tray.
- High-efficiency heat exchange coil in copper tube and aluminium fins, standard connections on the right side.
- Double-intake centrifugal fans with plastic fans with forward curved blades, wing profile, large diameter, mounted on elastic supports and shock absorbers.
- The unit is equipped with an IP20 "Mammoth" type terminal box mounted on the outside of the unit.
- The HCN series ductable units are supplied without an air filter. A wide range of filters is available in the accessories section.

### Versions



**S-OIP** Single panel, horizontal naked terminal, rear air intake



**S-OII** Single panel, horizontal naked terminal, bottom air intake



**D-OIP** Double panel, horizontal naked terminal, rear air intake



**D-OII** Double panel, horizontal naked terminal, bottom air intake

### Versions

**S-OIP** Single panel, horizontal naked terminal, rear air intake

**D-OIP** Double panel, horizontal naked terminal, rear air intake

**S-OII** Single panel, horizontal naked terminal, bottom air intake

**D-OII** Double panel, horizontal naked terminal, bottom air intake

### Nomenclature

When ordering, always specify complete model like the example.

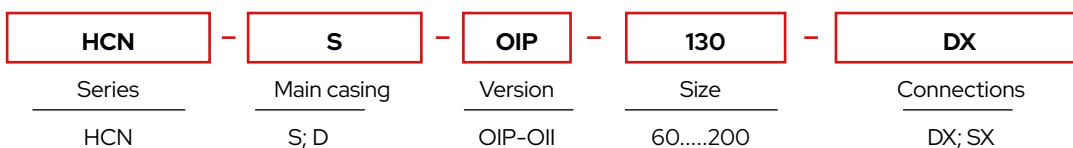

**HCN-S-OIP 130-DX**

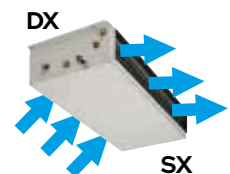

HCN			60	75	86	103	130	136	150	170	200
Cooling capacity (1) (*)	W		6.010	7.480	8.590	10.300	12.900	13.600	15.000	17.200	20.200
Sensible capacity (1) (*)	W		4.570	5.560	6.160	8.100	9.950	10.800	11.100	13.300	14.900
Heating capacity (2) (*)	W		6.550	7.900	8.300	11.700	14.400	15.650	15.200	19.400	20.400
Heating capacity (3) (*)	W		13.100	15.800	16.600	23.400	28.800	31.300	30.400	38.800	40.800
Portata d'aria (4)	m³/h		1.100	1.200	1.150	2.100	2.300	2.800	2.200	3.100	2.950
Sound pressure Min-Med-Max (5)	dB(A)		37-44-49	38-45-50	38-45-50	45-50-52	46-51-53	41-48-51	46-51-53	42-49-52	42-49-52
Nominal power consumption	W		200	200	200	340	340	340	320	320	320
Rated current	A		0,9	0,9	0,9	1,65	1,65	1,65	1,50	1,50	1,50
N° motors / n° fans			1 / 1	1 / 1	1 / 1	1 / 2	1 / 2	1 / 2	1 / 3	1 / 3	1 / 3
Maximum useful static pressure	Pa		148	152	152	138	142	142	132	136	136
n° of rows	n°		3	3	4	3	3	4	3	3	4
Mixed battery hot/cold	hydraulic connection	ø	3/4" F	3/4" F	3/4" F	3/4" F	3/4" F	3/4" F	3/4" F	3/4" F	3/4" F
	water content	L	1,95	1,96	2,60	2,86	2,87	3,82	3,75	3,76	4,99

Heat outputs in 4-pipe version (HCN + BC)											
HCN			60	75	86	103	130	136	150	170	200
Cooling capacity (1) (*)	W		5.830	7.220	-	9.960	12.400	-	13.200	16.600	-
Sensible capacity (1) (*)	W		4.220	5.350	-	7.830	9.530	-	10.400	12.800	-
Heating capacity (3)	W		6.610	6.970	-	11.600	12.200	-	15.500	16.400	-
Air flow (4)	m³/h		1.050	1.140	-	2.000	2.170	-	2.670	2.930	-
Maximum useful static pressure	Pa		148	152	-	138	142	-	134	138	-

Note: Yields and air flow rates refer to the AC motor version, at 0 Pa head conditions. For different useful heads refer to air flow rate variation diagrams.

(1) Inlet air temperature: 27°C b.s./19.5°C b.u.

Inlet/outlet water temperature: 7°C / 12°C

(2) Inlet air temperature: 20°C b.s.

Inlet / outlet water temperature: 45°C / 40°C

(3) Inlet air temperature: 20°C b.s.

Inlet / outlet water temperature: 70°C / 60°C

(4) Nominal values measured with box ref. standards AMCA210-74 and duct + diaphragm ref. standards CNR-UNI10023

(5) In free field, distance 3 m. Values calculated from sound power measured in reverberation chamber ref. standards ISO3740 - ISO3742

(1)(2)(3)(4)(5) Nominal technical data ref. air flow rate (4) at max. speed and free field unit

(\*) Maximum speed

DN=Nominal diameter; F=Female gas connections

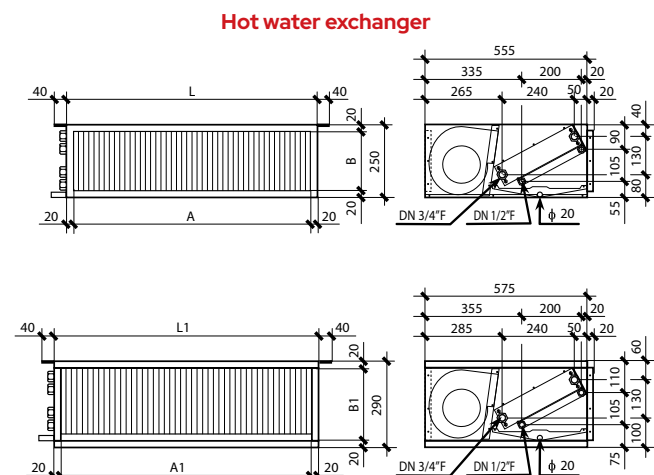
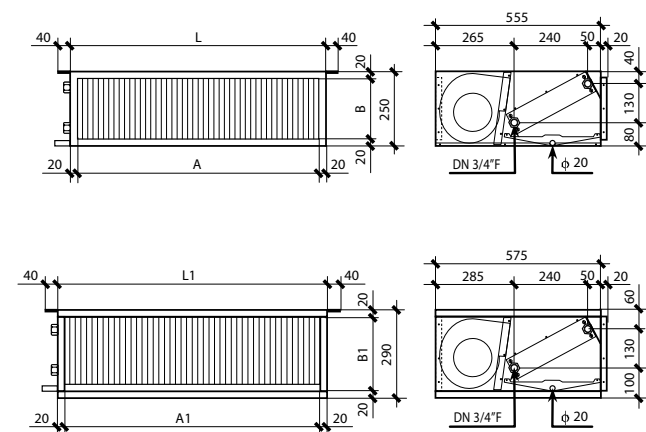

**Version "S"**

HCN		60	75	86	103	130	150	136	170	200
L	mm	800	800	800	1.200	1.200	1.200	1.600	1.600	1.600
A	mm	760	760	760	1.160	1.160	1.160	1.560	1.560	1.560
B	mm	210	210	210	210	210	210	210	210	210
Weight	kg	34	35	37	48	50	53	63	65	68

**Version "D"**

HCN		60	75	86	103	130	150	136	170	200
L1	mm	840	840	840	1.240	1.240	1.240	1.640	1.640	1.640
A1	mm	800	800	800	1.200	1.200	1.200	1.600	1.600	1.600
B1	mm	250	250	250	250	250	250	250	250	250
Weight	kg	48	49	51	66	68	71	85	87	90

**Version "S" - Hot water exchanger**

HCN		60	75	103	130	136	170
L	mm	800	800	1.200	1.200	1.600	1.600
A	mm	760	760	1.160	1.160	1.560	1.560
B	mm	210	210	210	210	210	210
Weight	kg	36	37	51	53	67	69

**Version "D" - Hot water exchanger**

HCN		60	75	103	130	136	170
L1	mm	840	840	1.240	1.240	1.640	1.640
A1	mm	800	800	1.200	1.200	1.600	1.600
B1	mm	250	250	250	250	250	250
Weight	kg	50	51	69	71	89	91

# HCNP

## Terminal units slim/reduced with Brushless DC and AC Asynchronous motor, powered

6,8 kW÷12 kW



- Self-supporting structure in galvanised sheet metal with thermal-acoustic insulation (S version) or 20 mm double sandwich panel with pre-painted white RAL 9002 external sheet metal (D version); with ceiling/wall fixing holes, small size and optimised overall dimensions.
- Double-sloped condensate drip tray.
- High-efficiency heat exchange coil in copper tube and aluminium fins, standard connections on the right side.
- In the HCN P series, double-intake centrifugal fans with plastic fans with forward curved blades, wing profile, large diameter, mounted on elastic supports and shock absorbers, are equipped with higher power motors to ensure higher useful static pressures.
- The unit is equipped with an IP20 'Mammoth' type terminal box mounted on the outside of the unit.
- The HCN P series ductable units are supplied without an air filter. A wide range of filters is available in the accessories section.

### Versions



**S-OIP** Single panel, horizontal naked terminal, rear air intake



**S-OII** Single panel, horizontal naked terminal, bottom air intake



**D-OIP** Double panel, horizontal naked terminal, rear air intake



**D-OII** Double panel, horizontal naked terminal, bottom air intake

### Versioni

**S-OIP** Single panel, horizontal naked terminal, rear air intake  
**D-OIP** Double panel, horizontal naked terminal, rear air intake

**S-OII** Single panel, horizontal naked terminal, bottom air intake  
**D-OII** Double panel, horizontal naked terminal, bottom air intake

### Nomenclature

When ordering, always specify complete model like the example.

<b>HCNP</b>	-	<b>S</b>	-	<b>OIP</b>	-	<b>120</b>	-	<b>DX</b>
Series		Main casing		Version		Size		Connections
HCNP		S; D		OIP-OII		68...120		DX; SX

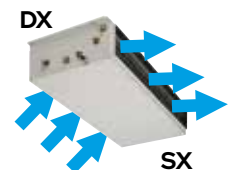

**HCNP-S-OIP 120-DX**

HCNP			68	86	101	120
Cooling capacity (1) (*)		W	6.820	8.650	10.100	12.000
Sensible capacity (1) (*)		W	5.300	6.580	7.380	9.780
Heating capacity (2) (*)		W	7.600	9.450	10.000	14.200
Heating capacity (3) (*)		W	15.200	18.900	20.000	28.400
Air flow (4)		m³/h	1.350	1.500	1.450	2.750
Sound pressure Min-Med-Max (7)		dB(A)	34-43-49	35-44-50	35-44-50	37-48-51
Nominal power consumption		W	270	270	270	570
Rated current		A	1,25	1,25	1,25	2,70
N° motors / n° fans			1/1	1/1	1/1	1/2
Maximum useful static pressure		Pa	184	194	194	182
Mixed battery hot/cold	n° of rows	n°	3	3	4	3
	hydraulic connection	∅	3/4" F	3/4" F	3/4" F	3/4" F
	water content	L	1,95	1,95	2,60	2,86

**Heat outputs in 4-pipe version (HCNP + BC)**

HCNP			68	86	101	120
Cooling capacity (1) (*)		W	6.570	8.280	11.500	14.600
Sensible capacity (1) (*)		W	5.070	6.250	9.330	11.500
Heating capacity (3)		W	12.100	12.900	22.300	23.600
Air flow (4)		m³/h	1.270	1.400	2.570	2.800
Maximum useful static pressure		Pa	186	196	184	192

Note: Yields and air flow rates refer to the AC motor version, at 0 Pa head conditions. For different useful heads refer to air flow rate variation diagrams.

(1) Inlet air temperature: 27°C b.s./19.5°C b.u.

Inlet/outlet water temperature: 7°C / 12°C

(2) Inlet air temperature: 20°C b.s.

Inlet / outlet water temperature: 45°C / 40°C

(3) Inlet air temperature: 20°C b.s.

Inlet / outlet water temperature: 70°C / 60°C

(4) Nominal values measured with box ref. standards AMCA210-74 and duct + diaphragm ref. standards CNR-UNI10023

(7) In free field, distance 3 m. Values calculated from sound power measured in reverberation chamber ref. standards ISO3740 - ISO3742

(1)(2)(3)(4)(5)(6) Nominal technical data ref. air flow rate (4) at max. speed and free field unit

(\*) Maximum speed

DN=Nominal diameter; F=Gas connections female

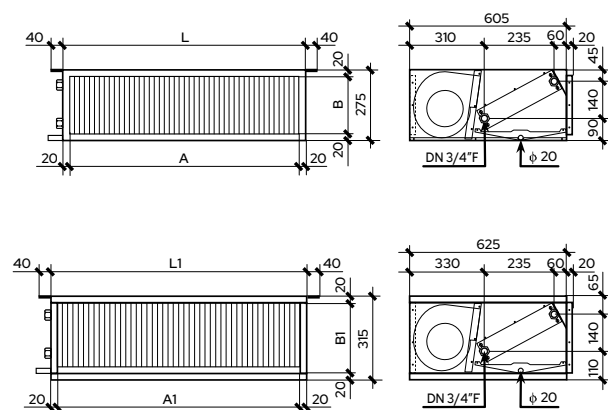

**"S" version**

HCNP		68	86	101	120
L	mm	800	800	800	1.200
A	mm	760	760	760	1.160
B	mm	235	235	235	235

**Version "S" - Hot battery**

HCNP		68	86	101	120
L	mm	800	800	800	1.200
A	mm	760	760	760	1.160
B	mm	235	235	235	235

**Hot battery**

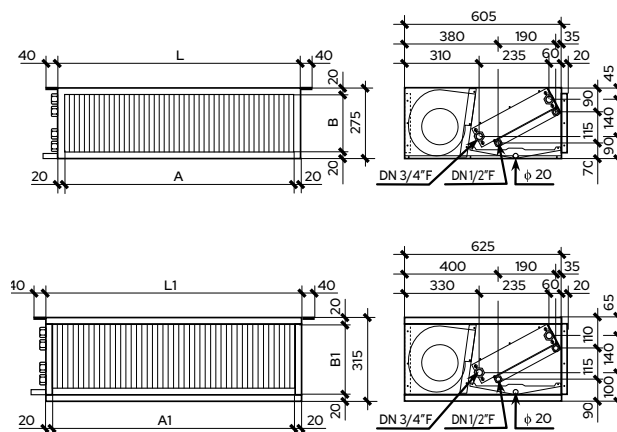

**"D" version**

HCNP		68	86	101	120
L1	mm	840	840	840	1.240
A1	mm	800	800	800	1.200
B1	mm	275	275	275	275

**Version "D" - Hot battery**

HCNP		68	86	101	120
L1	mm	840	840	840	1.240
A1	mm	800	800	800	1.200
B1	mm	275	275	275	275

**HCN, HCNP: Fitted accessories**

**BC** Auxiliary heating coil, 2 rows

**RE** Electrical heater integrated inside the units + "TS" safety thermostat (without power relay) 230V/50Hz/1Ph

**MOR TMB** Mammoth type terminal board + water low temperature thermostat. Tset 32°C. All HCN units are supplied with standard Mammoth type terminal board, without thermostat.

**TEL** Remote control management system .Motherboard + Air sensor + Water sensor - I.R. receiver + I.R. Remote control (control 2-4 pipe units, with/without valves). Fan 7A-230Vac. Valves: 2A-230Vac.

**SND W4** Water temperature probe (type NTC 4700 Ohm @ 25°C) with minimum temperature settable. Cable length 1 meter. Alternative to TMB thermostat.

**SFA-S SFA-D** Flat air filter (not ductable), EU3 filtering level. (S=single skin panel made of galvanized steel, D=double skin panel pre-painted)

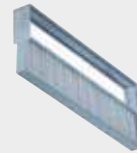
**MB** Brushless motor with continuous variation 0-100% of the air flow (signal 0..10 Vdc) Digital wall thermostat is an essential accessory for the operation of a unit with Brushless motor. Should not be combined with accessory TEL

**SFC-S SFC-D** Ductable air filter section + flat air filter, EU3 filtering level (S=single skin panel made of galvanized steel, D=double skin panel pre-painted)

**3V-2,5 3V-4 3V-6** 3-way valve with actuator 230V for 2 pipes units

**3VM-2,5 3VM-4 3VM-6** 3-way valve with actuator 24Vac for 2 pipes units, Modulating signal 0-10V

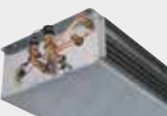
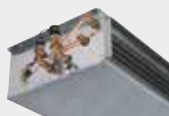
**2V-2,5 2V-4 2V-6** 2-way valve with actuator 230V for 2 pipes units

**2VM-2,5 2VM-4 2VM-6** 2-way valve with actuator 24Vac for 2 pipes units, Modulating signal 0-10V

**3VC-2,5 3VC-4 3VC-6** 3-way valve for heating coil (4-pipe unit) with actuator 230V

**3VCM-2,5 3VCM-4 3VCM-6** 3-way valve for heating coil (4-pipe unit) with actuator 24Vac, Modulating signal 0-10V

Quadro elettrico per sezione elettrica 230Vac  
(BOX+magnetotermico+relè)

**QR1**

Modello	Potenza	Compatibilità HCN	Compatibilità QR1
RE0.7-24	0,7 kW / 3,1 A	Tutte le taglie	QR1-0,7
RE1.0-24	1,0 kW / 4,4 A	Tutte le taglie	QR1-1,4
RE1.5-24	1,5 kW / 6,6 A	Tutte le taglie	QR1-2,3
RE2.0-24	2,0 kW / 8,7 A	Tutte le taglie	QR1-2,3
RE3.0-24	3,0 kW / 13,1 A	HCN 103-130-150-136-170-200	QR1-3,7

## HCN, HCNP: Fitted accessories

Ductable air filter section + HIGH EFFICIENCY ondulated air filter H=100mm, EU5 filtering level (S=single skin panel made of galvanized steel, D=double skin panel pre-painted)

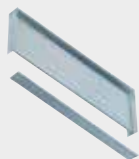

**SFD-S**  
**SFD-D**

Air press. drop (clean/dirty filter)

	HCN	60	75	86	103	130	150	136	170	200
SFA (Pa)		15/35	17/42	16/38	23/55	27/66	25/60	22/54	28/66	25/60
SFC (Pa)		15/35	17/42	16/38	23/55	27/66	25/60	22/54	28/66	25/60
SFD (Pa)		20/37	24/44	22/41	32/59	38/70	35/64	31/58	39/71	35/64

Power electric board for heaters 230Vac (BOX+magnetothermic+relè)



**QR1**

Model	Power	HCN Compatibility	QR1 Compatibility
RE0.7-24	0,7 kW / 3,1 A	All size	QR1-0,7
RE1.0-24	1,0 kW / 4,4 A	All size	QR1-1,4
RE1.5-24	1,5 kW / 6,6 A	All size	QR1-2,3
RE2.0-24	2,0 kW / 8,7 A	All size	QR1-2,3
RE3.0-24	3,0 kW / 13,1 A	HCN 103-130-150-136-170-200	QR1-3,7



**2VC-2,5** 2-way valve for heating coil  
**2VC-4** (4-pipe unit) with actuator  
**2VC-6** 230V

**2VCM-2,5**  
**2VCM-4**  
**2VCM-6**

2-way valve for heating coil (4-pipe unit) with actuator 24Vac, Modulating signal 0-10V

Note: Every single kit includes one valve and one actuator. In case of 4-pipe system must be provided n° 2 valves. For example, with ducted 4-pipe, in the case of 3-way valves, power supply 230 V: 3V + 3VC

### 3/2 way valve characteristics - RECOMMENDED MATCHINGS

HCN	60	75	86	103	130	150	136	170	200	
Valve characteristics	Kvs 2,5		Kvs 4			Kvs 6				
User side connection					DN 3/4" M					
Nominal pressure					PN 16 bar					

**HCN, HCNP: Loose accessories**



**PMP**

Condensate pump provided with 8A (250V)



**MS**

Motor "230Vac on-off" suitable for air damper



**SDI.4X3A**

Card with 4 by 3A output (suitable to control up to max No. 4 3-Speed 3A motors ; ex. No. 4 small fan-coils)  
Contatti-Contacts: 4x 3(0,3)A 230Vac



**SDI.2X10A**

Card with 2 by 10A output (suitable to control up to max No. 2 3-Speed motors of 10A ; ex. No. 1 large unit with 2 motors)  
Contatti-Contacts: 2x 10A-230Vac



**S2S-S  
S2S-D**

Closed section + 2 Regulation/adjustment louvers (1 louver below + 1 louver on the rear side) - Louvers without controls - can be either manual or motorized control (S=single skin panel made of galvanized steel, D=double skin panel pre-painted)



**SSL-S  
SSL-D**

Labyrinth noise level attenuator section, suitable for both air intake/supply outlets (S=single skin panel made of galvanized steel, D=double skin panel pre-painted)

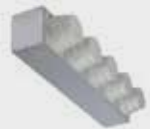

**Scm-S  
Scm-D**

Steel section with spigots "Ø" with variable diameter made of plastic material, external insulation (S=single skin panel made of galvanized steel, D=double skin panel pre-painted)

N° and Ø spigots

HCN	60	75	86	103	130	150	136	170	200
SCM n° x Ø	3xØ200/180/160			5xØ200/180/160			6xØ200/180/160		

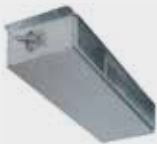

**SSM-S  
SSM-D**

External/Internal mixing section "external air 0-33% - internal air 100-67% or vice versa (coupled louvers with manual controls - can be motorized) (S=single skin panel made of galvanized steel, D=double skin panel pre-painted)

Air pressure drop

HCN	60	75	86	103	130	150	136	170	200
SSM (Pa)	13	15	14	20	24	22	20	24	22
S2S (Pa)	15	17	16	23	27	25	22	28	25



**SBC-O**

Auxiliary drain pan made of galvanized steel- thermal insulation

(1) Each control panel can control only one unit. To controll more units see SDI accessory